

Static Pressure Alarm For Hazardous Location Fume Hoods

Model: ASP-XPA1

120V/15A/60 Hz



Contents:

- General Description
- Contents of box
- Installation
- Adjustment
- Operation
- Safety
- Specifications
- Warranty statement
- Components

Represented By:
Holland Safety Equipment
726 McKinley Ave., Libertyville, IL 60048
Phone: 847-680-9930
www.hollandsafety.com

General Description

Intended for use in laboratories that are classified as a hazardous location, the explosion-proof low pressure alarm provides continuous monitoring of the negative static pressure in the fume hood exhaust duct. During normal negative static pressure conditions, the alarm illuminates a green indicator LED. When static pressure in the exhaust duct is insufficient, an audible alarm sounds and a red LED indicator illuminates. To maintain the integrity of the certified explosion proof instrument enclosure, the functionality of the test/reset button is performed using a light sensor. Covering the light sensor momentarily acknowledges the alarm and silences the horn for 10 minutes. During periods of darkness, the alarm functions normally but the test/reset function is unavailable. An output relay is provided to signal a remote alarm if needed.

All electrical housings are UL or FM approved for Class 1, Div 1, Groups B, C and D.

Standard buzzer is Class 1, Div 2, optional buzzer is Class 1, Div 1.

Box Contents:

The box contains the following items:

- Control Box including main circuit board
- Operator Display unit
- Dwyer 1950G explosion proof pressure switch
- Static pressure duct probe tube
- 15 feet of ¼" polyethylene tubing
- Federal Signal explosion proof horn model 350WBX-120 for Class 1, Div 2 compliance or model 31X-120-3 for Class 1, Div 1 compliance

Installation

Installation consists of the following general steps:

- Mount the control box
- Mount the pressure switch
- Mount the operator display unit
- Mount the buzzer
- Wire the control box to the operator display panel
- Wire the control box to the pressure switch
- Wire the control box to the buzzer
- Wire 120v mains supply to control box

The following steps must be completed after the hood has been installed and the exhaust system is operational and both exhaust and supply airflow for the laboratory has been properly balanced.

- Install the static pressure probe in the duct above the fume hood
- Connect tubing from the low pressure port on the pressure switch to the static pressure port

- Verify hood flow and adjust the pressure switch to the minimum setting which maintains a green indication

Detailed Installation Instructions:

In most cases it will be expedient to pre-assemble some or all of the wiring on the bench before mounting the enclosures to the fume hood therefore the sequence of work listed below may be modified as needed.

All items must be mounted such that moving parts like the sash, sash counterbalance, chain or cable do not rub against them. Generally speaking it is not acceptable to penetrate the fume hood liner when mounting these items – consult the fume hood manufacturer if in doubt. All items must be accessible for servicing in the future.

Mount the control box

The control box should be securely mounted on the roof of the fume hood using suitable fasteners.

Mount the Pressure Switch

The pressure switch should be securely mounted in a vertical position using suitable fasteners in accordance with the included instruction sheet (also available as Appendix A in this manual)

Mount the Operator Display Unit

The operator control panel is designed to be mounted to the face of the fume hood and should be accessible to the operator of the fume hood at all times. A moderate amount of ambient light is needed to provide access to the test/reset function. A bracket is provided for the installation of two, #8 sheet metal screws which should be oriented at the top. The conduit entry should be at the bottom and normally an elbow is used to allow the explosion proof cable to enter the hood side wall for routing to the main control panel.

Mount the Buzzer

The buzzer should be securely mounted to the roof of the fume hood using suitable fasteners. Details on the buzzer are available in Appendix B.

Wiring

Wiring must be performed by a licensed electrician in a manner acceptable to the local authorities and in accordance with the most recent edition of the National Electrical Code. In general type MC-HL cable and listed glands can be used, but in some cases rigid conduit and listed sealing fittings will be required.

14 gauge wire is recommended for connection between the control box and the buzzer and the pressure switch. The connection between the Control Box and the Operator Display Unit is low voltage and lighter gauge wire may be used if available.

The alarm system should be connected to a dedicated 15A/120V circuit.

Figure 1 shows connections that must be made. Ground wires are not shown - note that ALL BOXES must be grounded in accordance with the NEC and local codes.

For alarm configurations making use of the remote alarm output, it is necessary to connect the main control box to another junction box using a short length of multi-conductor cable or conduit with appropriate seals. This will allow for the connection of the additional cables needed to implement the remote alarm feature.

After wiring, each housing, including circuit boards must be re-assembled exactly as they were and covers must be installed and tightened.

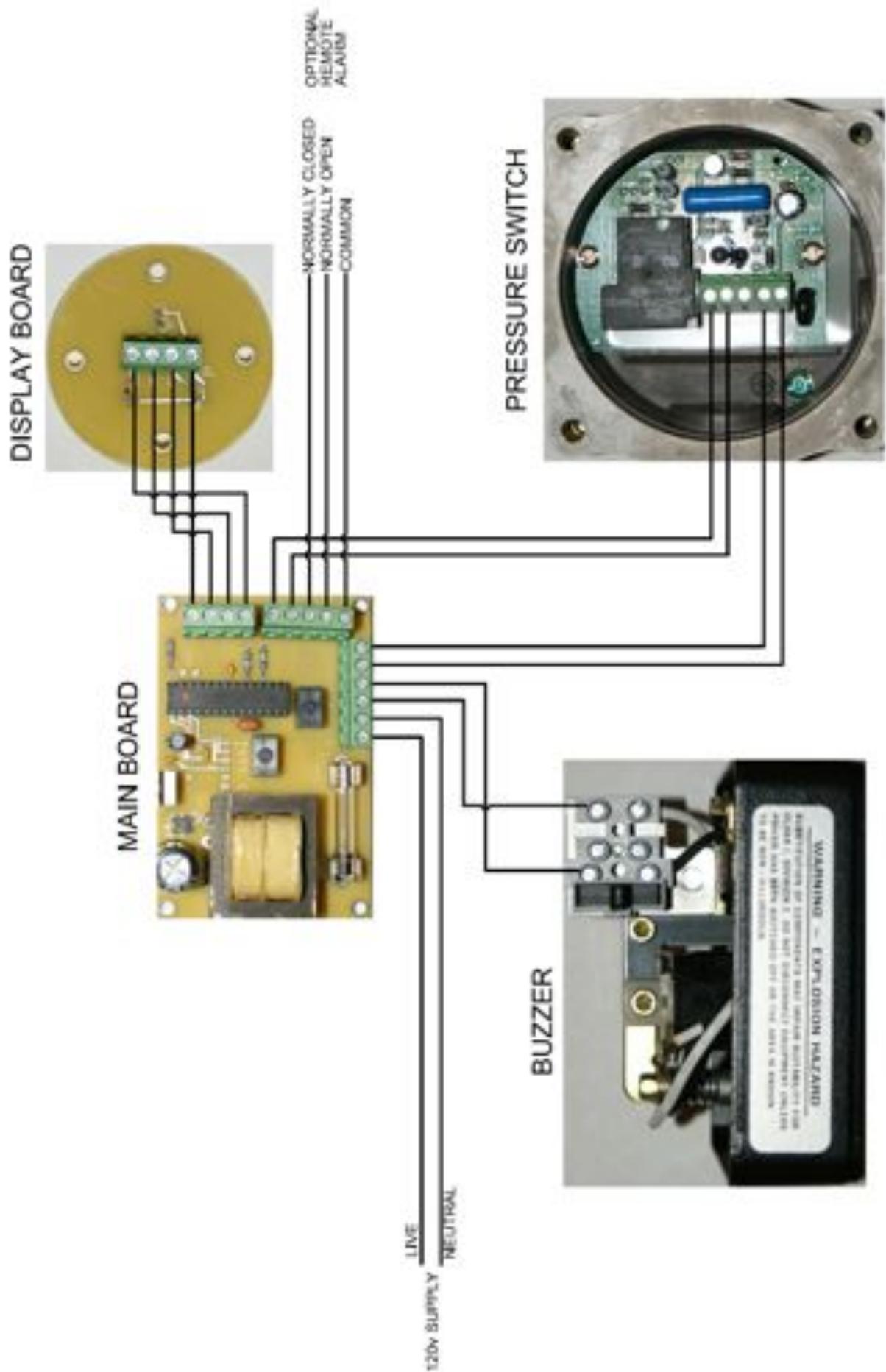

FIGURE 1

Install the Static Pressure Probe

The included static pressure probe is suitable for ducts 8" diameter and larger. It should be located at least one duct diameter above the fume hood in a straight section of ducting.

Drill a 5/16" diameter hole in the duct above the fume hood. Install the static pressure probe in the duct using the included foam rubber gasket and self-drilling sheet metal screws.

Attach the ¼" polyethylene hose from the fitting on the static pressure probe to the LOW port on the pressure switch using the included adapter.

Ensure that the hose is not allowed to chafe on any moving parts including the sash, counterweight and cables or chains.

Leave the high port open. If the pressure switch is located in a space that is not at the same pressure as the laboratory, then connect suitable hose to the HIGH port and run this hose into the laboratory space.

Adjusting the alarm set point

The ASP-XPA1 Airflow Monitor must be calibrated before first use and checked regularly thereafter. Fume hoods vary in design and performance. Because each hood installation and its airflow pattern is unique, this monitor must be calibrated in the field on the fume hood in which it is installed.

WARNING

Calibration of this instrument should only be performed by qualified personnel. Proper guidelines for monitoring any ventilation apparatus are established on the basis of toxicity or hazards of the materials used, or the operation conducted within the ventilation apparatus. Personnel calibrating the ASP-XPA1 must be completely aware of the regulations and guidelines specific to its application. If you need a reference on performing traverses on fume hoods, please consult the latest edition of ASHRAE 110 *Method of Testing Performance of Laboratory Fume Hoods*, section 6.2 Face Velocity Measurements.

Tools Required

1. Calibrated thermo-anemometer rated for hazardous environments.
2. Small slotted screwdriver.

Procedure

1. Double check installation to verify that the monitor, power supply, and any ancillary equipment are properly installed.
2. Allow at least 10 minutes for the pressure switch to warm up.
3. Determine the alarm set point. This is the condition where the monitor will indicate a low flow condition. The red LED on the Operator Panel will light at this point. Consult the facility's Industrial Hygiene Officer for the proper set point.

NOTE: This device senses the duct static pressure. Different hoods may require different duct static pressure to generate the same face velocity.

4. Set the sash at the working height and adjust the fume hood airflow to the low alarm set point (as determined in step 3, above). One method is to close the volume damper (if available) in the ductwork. This damper must be downstream of the static pressure probe.

WARNING

This method is only used as a temporary means of setting the low flow set point. Make certain that airflow is restored to the proper level after calibration.

5. Using a properly calibrated thermo-anemometer, determine the velocity through the face of the hood by taking a detailed velocity traverse. Divide the face area of the hood into equal partitions. One reading per square foot of face area is recommended for an accurate traverse. Compute the average velocity for this area. Temporarily adjust the airflow of the fume hood as in step 4 above until the average face velocity is near the desired low flow alarm set point.

NOTE: The pressure switch response time may be as long as 10 to 25 seconds when the applied pressures are near the set point.

6. If the red LED is initially lit, slowly turn the adjustment screw on the pressure switch clockwise until the green LED lights and then slowly turn the adjustment screw counter-clockwise until the red LED again lights. If the green LED is initially lit, slowly turn the adjustment screw on the pressure switch counter clockwise until the red LED lights.

IMPORTANT: To allow for the delayed reaction of the pressure switch, these adjustments must be made in small increments, at intervals up to 25 seconds each.

7. Restore normal airflow to the fume hood.

NOTE: Due to the hysteresis of the pressure switch, the sash of the fume hood may need to be nearly closed to generate sufficient duct static pressure to reset the pressure switch to a “good” flow (green LED lit) condition. Upon restoring the airflow to the normal level, drop the sash down to reset the alarm to a non-alarm status and then return the sash to the working height. The green LED should remain lit.

8. Verify the alarm setting by establishing a low flow condition (as in step 4). If the alarm does not activate, repeat steps 5 through 8.

Operation

During normal operation, the static pressure alarm operator display panel should give a green indication. This indicates that the pressure switch is sensing negative pressure in the fume hood exhaust duct in the normal range as established by the calibration procedure. While the unit is indicating in the green, the audible and visible alarm may be tested by momentarily covering and uncovering the light sensor (within one second). The indicator lights will flash and the audible alarm will sound twice. In order to provide access to other functions, this test may be performed only once every 30 seconds.

In the event that the alarm sounds, it is generally because a loss of static pressure has been detected in the fume hood exhaust. At this time, the fume hood sash should be lowered to re-establish adequate static pressure. If the alarm does not reset, it is likely that the exhaust system has failed. Stop using the fume hood for active experiments, close the sash and evacuate the laboratory if the chemicals or fumes pose an immediate hazard.

If the low flow condition is expected and no hazard is present in the hood (such as during experiment set-up or tear-down) then the alarm may be temporarily silenced by momentarily covering and uncovering the light sensor. The temporary muting of the alarm will last for approximately 10 minutes after which time normal operation will resume.

In the event that the fume hood will be decommissioned for an extended period of time, the alarm can be permanently muted by covering and uncovering the light sensor seven to eight times within a 30 second period. Successful completion of this procedure will result in both red and green LED's flashing three times. While the audible alarm is muted, the green or red led will be flashing as opposed to solid. The same procedure will re-enable the audible alarm. If the power supply to the alarm is interrupted, then it will reset to normal operation.

Safety

Before opening unit for servicing, ensure no hazardous or explosive fume are present, disconnect power and lock-out.

Specifications

Voltage:	120VAC
Frequency:	60 Hz
Current:	1A
Mains Breaker:	Switch/Breaker 15A
Mounting:	Surface Mount
Alarm Pressure Range:	0.07 to 0.15 inches water
Alarm relay output:	Normally open and Normally closed volt-free contacts Contacts rated 0.5A at 125 VAC / 1A at 24 VDC
Visual Indicators:	Green LED - static pressure OK Red LED - static pressure FAIL
Audible Indicator:	Intermittent Buzzer - 94 dB at 10 feet
Horn Silence:	Temporary with 10 minute self-reset Permanent until re-enabled or power-cycle
User Input:	Alarm is silenced and tested through the use of an ambient light sensor located behind sealed window in explosion proof housing
Wiring method:	Installer supplies explosion proof wiring materials and glands.
Calibration:	Single point pressure setting
Agency Listings:	All housings FM or UL listed

Specifications subject to change without notice

Warranty

LIMITATION OF WARRANTY AND LIABILITY

The Manufacturer warrants the goods sold hereunder, under normal use and service as described in the operator's manual, shall be free from defects in workmanship and material for TWELVE (12) months, or the length of time specified in the operator's manual, from the date of shipment to the customer. This warranty period is inclusive of any statutory warranty. This limited warranty is subject to the following exclusions:

- The manufacturer does not provide additional warranty on major components manufactured by others - only the original manufacturer's warranty applies.
- Unless specifically authorized in a separate writing by manufacturer, the manufacturer makes no warranty with respect to, and shall have no liability in connection with, goods which are incorporated into other products or equipment, or which are modified by any person other than the manufacturer.

The foregoing is IN LIEU OF all other warranties and is subject to the LIMITATIONS stated herein. **NO OTHER EXPRESS OR IMPLIED WARRANTY OF FITNESS FOR PARTICULAR PURPOSE OR MERCHANTABILITY IS MADE.**

TO THE EXTENT PERMITTED BY LAW, THE EXCLUSIVE REMEDY OF THE USER OR BUYER, AND THE LIMIT OF THE MANUFACTURER'S LIABILITY FOR ANY AND ALL LOSSES, INJURIES, OR DAMAGES CONCERNING THE GOODS (INCLUDING CLAIMS BASED ON CONTRACT, NEGLIGENCE, TORT, STRICT LIABILITY OR OTHERWISE) SHALL BE THE RETURN OF GOODS TO THE MANUFACTURER AND THE REFUND OF THE PURCHASE PRICE, OR, AT THE OPTION OF THE MANUFACTURER, THE REPAIR OR REPLACEMENT OF THE GOODS. IN NO EVENT SHALL THE MANUFACTURER BE LIABLE FOR ANY SPECIAL, CONSEQUENTIAL OR INCIDENTAL DAMAGES. THE MANUFACTURER SHALL NOT BE RESPONSIBLE FOR INSTALLATION, DISMANTLING OR REINSTALLATION COSTS OR CHARGES. No Action, regardless of form, may be brought against The manufacturer more than 12 months after a cause of action has accrued. The goods returned under warranty to the manufacturer's factory shall be at Buyer's risk of loss, and will be returned, if at all, at the manufacturer's risk of loss.

Buyer and all users are deemed to have accepted this LIMITATION OF WARRANTY AND LIABILITY, which contains the complete and exclusive limited warranty of MANUFACTURER. This LIMITATION OF WARRANTY AND LIABILITY may not be amended, modified or its terms waived, except by writing signed by an Officer of MANUFACTURER.

Components:

Operator Panel



Main Control Box and Cover

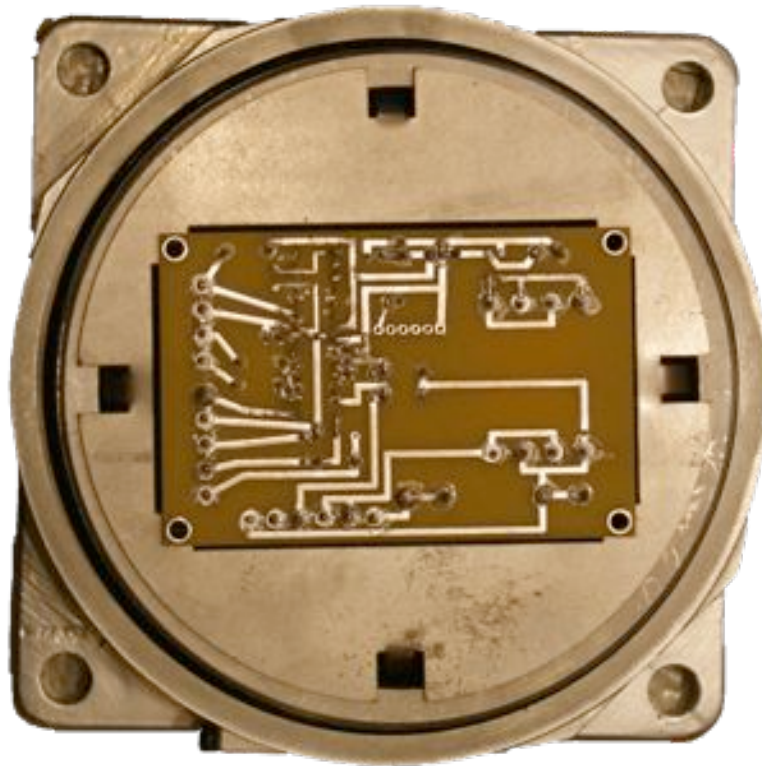

Pressure Switch



Buzzer



Static Pressure Probe





Series 1950G – Integral Explosion-Proof Pressure Switches

Specifications - Installation and Operating Instructions



The **Model 1950G Explosion-Proof Switch** combines the best features of the popular Series 1900 Pressure Switch with a compact explosion-proof housing.

This unit is UL, CSA, FM listed for use in Class I, Groups A*, B, C, D, Class II, Groups E, F, & G and Class III atmospheres and Directive 94/9/EC (ATEX) Compliant for **CE** II 2G Ex d IIB + H₂ T6. IECEx certified Ex d IIB + H₂ T6 (-40°C < Ta < +60°C) units are available. It is also totally rain-tight for outdoor installations. Six models allow set-points from 0.07 to 20 inches W.C. (1.78 mm to 508.0 mm W.C.).

Easy access to the SPDT relay for electrical hook-up is provided by removing the top plate of the aluminum housing. A captive screw allows the cover to swing aside while remaining attached to the unit. Adjustment to the set point of the switch can be made without disassembly of the housing. The unit is very compact, about half the weight and bulk of equivalent conventional explosion-proof switches.

Attention: Units with the "NA" and "EC" suffixes are not Directive 94/9/EC (ATEX) compliant. These units are not intended for use in potentially explosive atmospheres in the EU. These units may be CE marked for other Directives of the EU.

*GR. A is Only.

UL, CSA, FM Listed For

CL I GR. A*, B, C, D • CL II GR. E, F, G • CL III

Directive 94/9/EC (ATEX) Compliant For

CE 0344 II 2G Ex d IIB + H₂ T6

EC-Type Certificate Number: KEMA 03ATEX2402 X

ATEX Standards:

EN60079-0: 2006

EN60079-1: 2007

IECEx Certified for:

Ex d IIB + H₂ IP54 T6 (-40°C < Ta < +60°C)

IECEx Certificate of Conformity:

IECEx TSA 08-0020X

IECEx Standards:

IEC 60079-0: 2004

IEC 60079-1: 2003

Model 1950G Switches:

Operating ranges and deadbands

To order specify Model Number*	Operating Range Inches, W.C.	Approximate Dead Band	
		At Min. Set Point	At Max. Set Point
1950G-00-B-___	0.07 to 0.15	0.04	0.06
1950G-0-B-___	0.15 to 0.5	0.06	0.11
1950G-1-B-___	0.4 to 1.6	0.11	0.29
1950G-5-B-___	1.4 to 5.5	0.4	0.9
1950G-10-B-___	3.0 to 11.0	0.9	1.8
1950G-20-B-___	4.0 to 20.0	1.2	3.0

* Specify either 24 for 24 VDC, 120 for 120 VAC or 240 for 240 VAC when ordering. Example: 1950G-00-B-120

* Add "NA" suffix for models with UL, CSA, and FM approvals only. Example: 1950G-00-B-120-NA

* Add "EC" suffix for models which are IECEx certified. Units with "EC" suffix feature no other approvals.

SPECIFICATIONS

Service: Air and compatible combustible gases.

Wetted Materials: Contact Factory

Temperature Limits: 0 to 140°F (-17 to 60°C). Note: Set point drift may occur with ambient temperature changes.

Pressure Limits: 45" w.c. (11.2 kPa) continuous; 10 psig (68.95 kPa) surge.

Enclosure Rating: IP54, NEMA 3, 7 and 9.

Switch Type: 1 Form C relay (SPDT).

Electrical Rating: 10A, 120/240 VAC, 28 VDC. Resistive 50mA, 125 VDC.

Power Requirements: 24 VDC ±10%, 120 or 240 VAC ±10% optional.

Electrical Connections: Internal Terminal Block.

Process Connections: 1/8" female NPT.

Mounting Orientation: Diaphragm in vertical position. Consult factory for other position orientations.

Set Point Adjustment: Screw type on top of housing.

Weight: 2 lb, 15.7 oz (1.35 kg).

DWYER INSTRUMENTS, INC.
P.O. Box 373 • Michigan City, IN 46361-0373, U.S.A.

Phone: 219/879-8000
Fax: 219/872-9057

www.dwyer-inst.com
e-mail: info@dwyer-inst.com

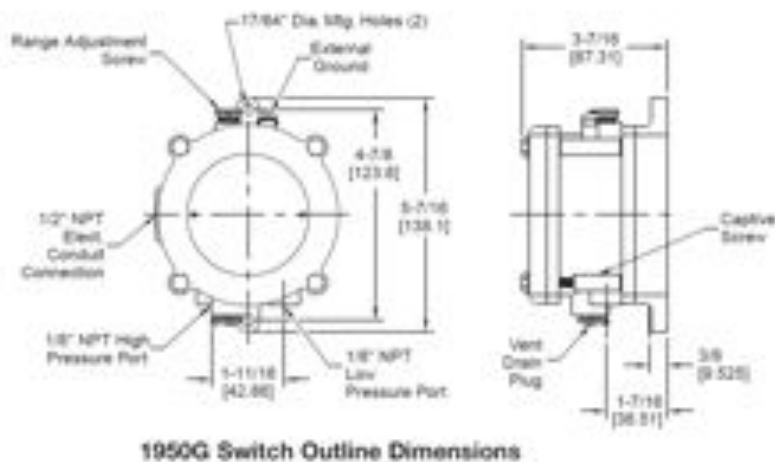

1950G Switch Outline Dimensions

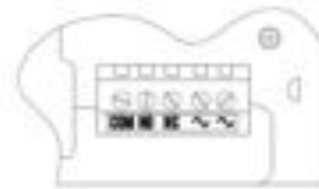

Fig. A

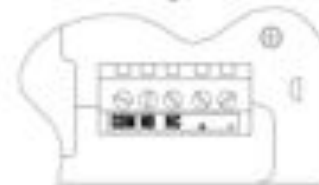

Fig. B

INSTALLATION

1. Select a location free from excess vibration and corrosive atmospheres where temperatures will be within the limits noted under Physical Data on page 1. Switch may be installed outdoors or in areas where the hazard of explosion exists. See page 1 for specific types of hazardous service.

2. Mount standard switches with the diaphragm in a vertical plane and with switch lettering and nameplate in an upright position. Some switches are position sensitive and may not reset properly unless they are mounted with the diaphragm vertical.

3. Connect switch to source of pressure, vacuum or differential pressure. Metal tubing with 1/4" O.D. is recommended, but any tubing which will not restrict the air flow can be used. Connect to the two 1/8" female NPT pressure ports as noted below.

A. Differential pressures - connect pipes or tubes from source of greater pressure to high pressure port marked HIGH PRESS, and from source of lower pressure to low pressure port marked LOW PRESS.

B. Pressure only (above atmospheric pressure) - connect tube from source of pressure to high pressure port. The low pressure port is left open to atmosphere.

C. Vacuum only (below atmospheric pressure) - connect tube from source of vacuum to low pressure port. The high pressure port is left open to atmosphere.

4. To make electrical connectors, remove the three hex head screws from the cover and after loosening the fourth captive screw, swing the cover aside. Electrical connectors to the standard single pole, double throw relay and AC supply voltage connections to the unit, are provided by means of terminals marked "COM", "NO", "NC", "+" and "-" (See Fig. A). Electrical connections to the standard single pole, double throw relay and DC supply voltage connections to the unit, are provided by means of terminals marked "COM", "NO", "NC", "+" and "-" (See Fig. B). The normally open contacts close and the normally closed contacts open when pressure increases beyond the setpoint. Switch loads for standard models should not exceed the maximum specified current ratings as stated on page 1. For ATEX and IECEx compliance, cables and cable glands suitable for temperature of at least 95°C shall be used. The cable entry device shall be of certified flameproof type, suitable for the conditions of use and be correctly installed. Refer to Certificate No.: IECEx TSA 08.00208 for conditions of safe use for IECEx Compliant units. Switch capabilities

decrease with an increase in ambient temperature, load inductance, or cycling rate.

ADJUSTMENT

To change setpoint:

A. Remove the plastic cap and turn the slotted Adjustment Screw at the top of the housing clockwise to raise the setpoint pressure and counter-clockwise to lower the setpoint. After calibration, replace the plastic cap and re-check the setpoint.

B. The recommended procedure for calibrating or checking calibration is to use a "T" assembly with three rubber tubing leads, all as short as possible and the entire assembly offering minimum flow restriction. Run one lead to the pressure switch, another to a manometer of known accuracy and appropriate range, and apply pressure through the third tube. Make final approach to the setpoint very slowly. Note that manometer and pressure switch will have different response times due to different internal volumes, lengths of tubing, fluid drainage, etc. Be certain the switch is checked in the position it will assume in use, (i.e. with diaphragm in a vertical plane) and switch lettering and Dwyer nameplate in an upright position.

C. For highly critical applications check the setpoint adjustment and if necessary, reset it as noted in step A.

MAINTENANCE

The moving parts of these switches need no maintenance or lubrication. The only adjustment is that of the setpoint. Care should be taken to keep the switch reasonably clean. Periodically the vent drain plug should be rotated then returned to its original position. This will dislodge deposits which could accumulate in applications where there is excessive condensation within the switch. Repairs to be conducted by Dwyer Instruments, Inc. Cover bolts are Class 10.9 35mm long.

Appendix B

MODEL 350WBX

**INSTALLATION INSTRUCTIONS FOR VIBRATONE HORN
MODEL 350WBX**

MODELO 350WBX

**INSTRUCCIONES DE INSTALACIÓN PARA LA BOCINA VIBRATONE
MODELO 350WBX**

MODELE 350WBX

**INSTRUCTIONS D'INSTALLATION POUR LE KLAXON VIBRATONE,
MODELE 350WBX**

Address all communications and shipments to:
Dirija todas la correspondencia y envios a:
Adressez toutes les communiations et expéditions à:



FEDERAL SIGNAL CORPORATION
Electrical Products Division
2645 Federal Signal Drive
University Park, IL 60466-3195

INSTALLATION INSTRUCTIONS FOR VIBRATONE HORN MODEL 350WBX

SAFETY MESSAGE TO INSTALLERS

NOTE

INSTALLATION, MAINTENANCE AND DISPOSAL OF THIS PRODUCT MUST BE CARRIED OUT IN ACCORDANCE WITH NATIONAL CODES AND STANDARDS.

It is important to follow all instructions shipped with this product. This device is to be installed by a trained electrician who is thoroughly familiar with and will follow all applicable national and local codes in the country of use.

The selection of the mounting location for the device, its controls and the routing of the wiring is to be accomplished under the direction of the Facilities Engineer and the Safety Engineer. In addition, listed below are some other important safety instructions and precautions you should follow:

- Read and understand all instructions before installing or operating this equipment.
- Do not connect this unit to the system when power is on.
- Optimum sound distribution will be severely reduced if any objects are in front of the speaker. You should ensure that the front of the speaker is clear of any obstructions.
- All effective warning horns produce loud sounds which may cause, in certain situations, permanent hearing loss. The device should be installed far enough away from potential listeners to limit their exposure while still maintaining its effectiveness. National Noise Standards, such as The OSHA Code of Federal Regulations 1910.95 in the United States, provide guidelines which may be used regarding permissible noise exposure levels.
- After installation, ensure that all mounting screws have been tightened.
- Establish a procedure to routinely check the sound system for proper activation and operation.
- Provide a copy of these instructions to the Safety Engineer, operator(s) and maintenance personnel.
- File these instructions in a safe place and refer to them when maintaining and/or reinstalling the device.

Failure to follow all safety precautions and instructions may result in property damage, serious injury, or death to you or others.

A. Introduction.

In all installations, it is recommended that the electrical wiring to the installation site be completed before the horn is mounted. Installations are subject to national and local electrical and fire codes and standards.

B. Installation.

WARNING

Do not connect wires when power is on.

The 350WBX is gasketed and has two 3/4-14 NPT and one 1/2-14 NPT tapped openings to accommodate supply connections.

1. Use the rear enclosure of the 350WBX as a template and mark the location of the mounting ears on the mounting surface. Secure the 350WBX to the mounting surface with user-supplied fasteners suitable for the mounting surface.
2. See figure 1. Remove and retain the four screws which secure the horn to the rear enclosure. Remove the horn from the rear enclosure.

3. Attach the supply wires to the terminal block as shown in figures 2 and 3. The terminal block is capable of accepting both solid and stranded wire within the range of 10 AWG (5.27 mm sq.) to 20 AWG (0.52 mm sq.). When using stranded wire, ensure that the strands of the wire are twisted together prior to inserting them into the terminal block.
4. Reassemble the horn to the rear enclosure using the previously removed screws.

WARNING

The device must be kept tightly closed while the circuits are energized.

SAFETY MESSAGE TO MAINTENANCE PERSONNEL

- Read and understand all instructions before performing any maintenance to this unit.
- To reduce the risk of electrical shock or ignition of hazardous atmospheres, do not perform maintenance/service on this device when circuits are energized.
- Optimum sound distribution will be reduced if the speaker becomes clogged with a foreign substance. Periodic checks should be performed to ensure foreign substances are not packed into the speaker.
- Any maintenance to the warning system must be performed by a trained electrician in accordance with all applicable national and local codes and standards in the country of use.
- Never alter the unit in any manner. Safety in hazardous locations may be endangered if additional openings or alterations are made in units specifically designed for use in these locations.
- The nameplate, which may contain cautionary or other information of importance to maintenance personnel, should not be obscured if the exterior of housings are painted.

Failure to follow all safety precautions and instructions may result in property damage, serious injury, or death to you or others.

C. Audibility and Electrical Ratings.

VOLTAGE	CURRENT (AMPS)	Hz	dB*	dB**
120	0.18-0.22	50-60	100	94
230-240	0.09	50-60	100	94

* MEASURED ON-AXIS AT TEN FEET / 3 METERS IN AN ANECHOIC CHAMBER.

** UNDERWRITERS LABORATORIES OMNIDIRECTIONAL SOUND PRESSURE LEVEL RATING AT TEN FEET.

D. Agency Approvals.

This product has been evaluated and approved by Underwriters Laboratories, Inc for the use in the following classified (hazardous) locations:

- Class I, Division 2, Groups A, B, C, D
- Class I, Zone 2, Group IIC
- Class II, Division 2, Groups F, G
- Class III

1

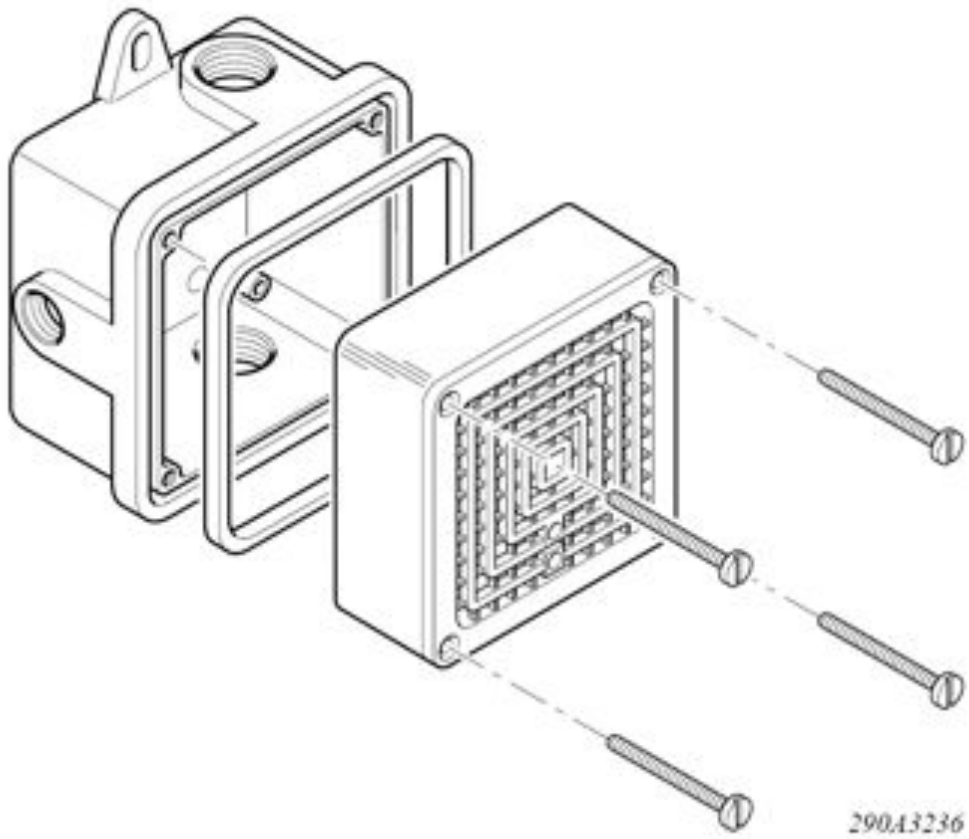

290.43236

2

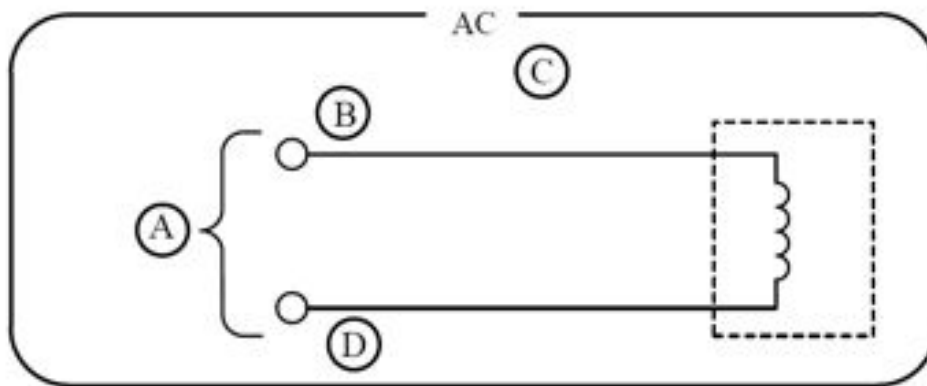

290.A3235B

English

- A. AC input power
- B. Standard AC horn wiring
- C. L, phase
- D. N, neutral

Español

- A. Potencia de entrada CA
- B. Cableado estandar CA la bocina
- C. L, fase
- D. N, neutral

3

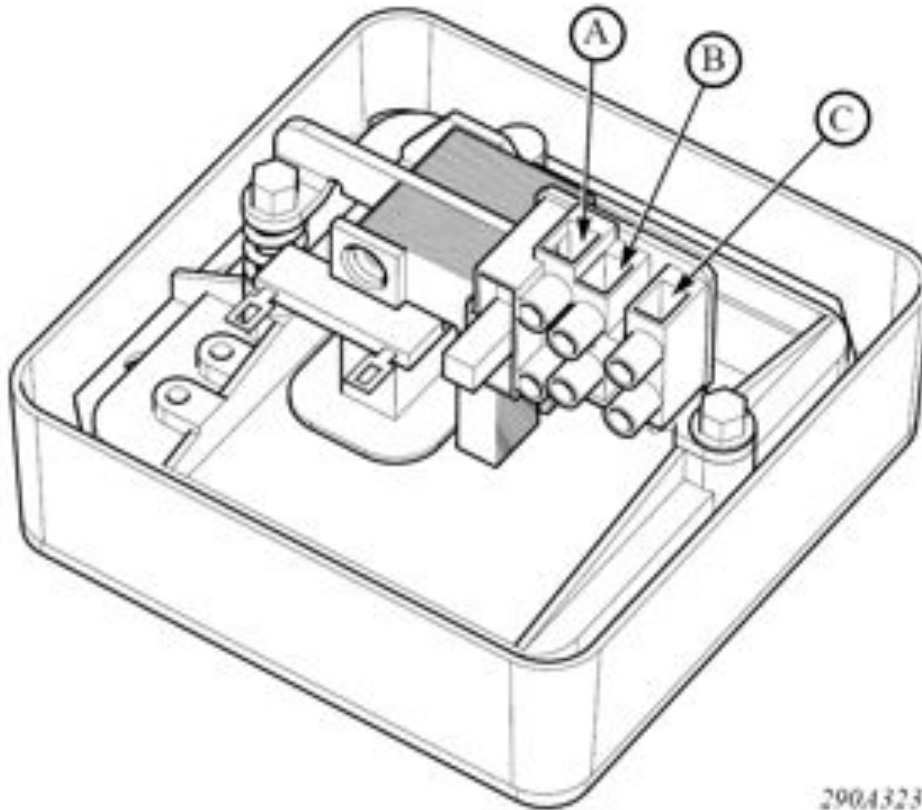

290A3237B

English

- A. Phase, L
- B. Ground
- C. Neutral, N

Español

- A. Fase, L
- B. Tierra
- C. Neutral, N

Français

- A. Phase, L
- B. Terre
- C. Neutre, N



FEDERAL SIGNAL CORPORATION

Electrical Products Division

8435A536E

Rev. E Printed 6/04

Printed in U.S.A.

**EXTERNAL VOLUME ADJUSTMENT FOR
THE MODEL 350 VIBRATORY HORN
(NOT FOR USE WITH THE 450 VIBRATORY HORN)**

Vibratory horns are shipped with the volume set for maximum sound output. However, the sound level can be reduced to any desired level with the 3/32" hex socket set screw provided. If the horn is a Model 350, install the screw at the location shown in the figure.

Before installing the set screw, thread hex washer head thread forming screw into the appropriate hole on the front of the horn. Remove the thread forming screw, and thread the set screw into the threaded hole. Use a 3/32 hex key wrench to rotate the set screw clockwise until the desired sound level is reached.

